

BURO SYNTRA HEIGHT ADJUSTABLE DESK Back to Back Workstation

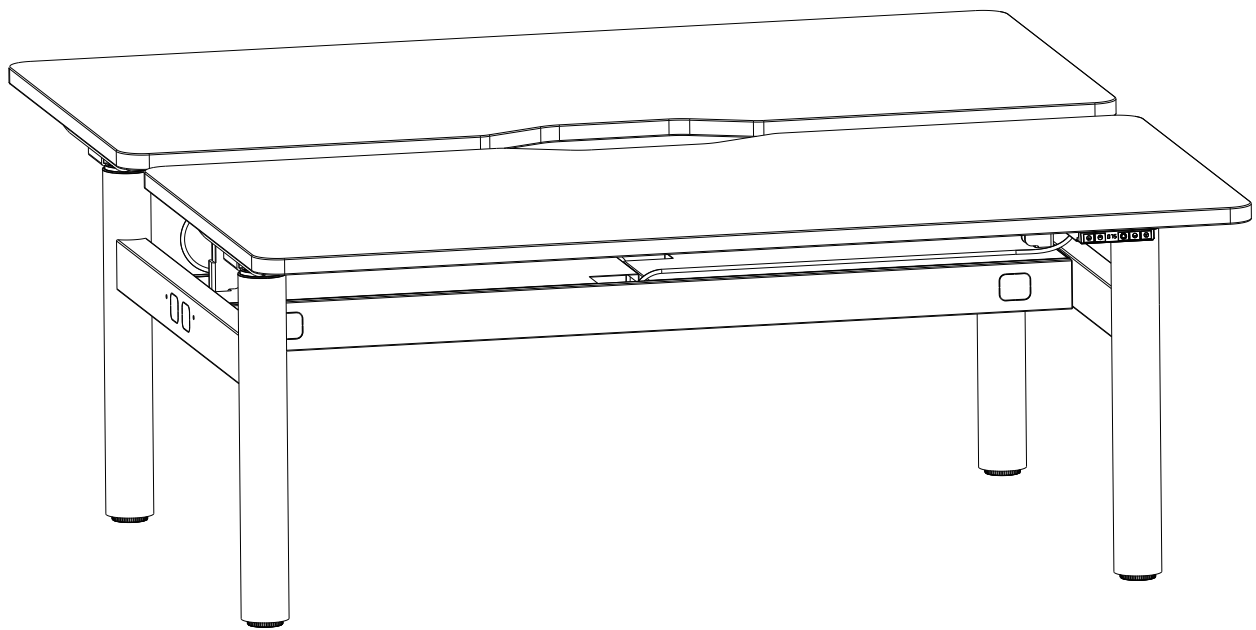

**TWO-PERSON
ASSEMBLY**

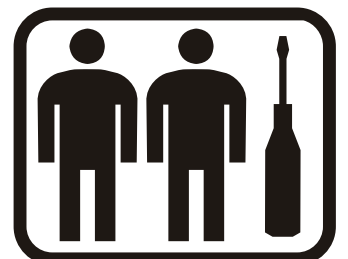

PREVENTATIVE MAINTENANCE & WARNING!

- This product complies with the prescribed safety regulations, misuse may cause damage to persons and product.
- Assemble on a clean, flat surface.
- Only use included tools to assemble the table.
- Do not climb, sit or stand on this table.
- Do not crawl, lie or move under this table.
- Children under 12 should only use the table when supervised.
- Do not place objects on the table when in motion.
- Do not use this table on an uneven floor surface.
- Do not use table unless all bolts, screws and brackets are tight. At least every three months check all bolts, screws and brackets to ensure they are tight.
- Distribute weight evenly across the table.
- Do not place heavy objects on the table.
- Do not place any objects higher than 60cm under the table.
- Place the table a safe distance from windows frames, furniture and other objects.
- Ensure no cables get jammed or pinched when the table is moving.
- The table is to only be used with the power supply unit provided. The use of any other power supply unit could cause the table to malfunction and could result in serious injury to the user.
- If any parts are missing, broken, damaged or worn do not use the product until repairs are made using factory authorised parts.
- Dispose of packaging properly.
- Plastic bags used for packaging are not toys.
- Do not use plastic bag as a head covering as it may cause suffocation.

CARE & MAINTENANCE

GENERAL CARE

- To maintain the appearance of the table, wipe the surface with a clean cloth dampened with a mild detergent solution.
- Do not remove any parts for separate cleaning.
- Do not saturate the table with water or other cleaning liquids.
- Do not place the table in a humid environment.
- Protect from direct sunlight, heat and weather.

GUARANTEE

TERMS AND CONDITIONS

Buro offers a 10 year guarantee (commencing from the date of purchase) to the original purchaser against faulty manufacture. This excludes fair wear and tear.

The guarantee is subject to the table being used for its designed purpose in normal office or home office conditions, a single-shift duration i.e., 40 hours per week. This includes acknowledging and adhering to Preventative Maintenance and Safety Warnings and Care and Maintenance guidelines above.

If the Buro product has been used outside Buro approved usage including weight limits, then the guarantee would be void.

If you would like to make a claim under the Buro Guarantee, please direct your enquiry to the Buro reseller you purchased the desk from. They will assess your product and where appropriate, will contact Buro to determine your claim. Buro staff will advise if the problem can be repaired on site or if the goods must be returned to Buro for repair. Return to base freight cost (from the reseller to Buro) will be paid by Buro provided Buro has given authority for the product return or accepted the guarantee claim.

CLAIM REQUIREMENTS

You must be able to:

- Prove you are the original purchaser
- Provide proof of purchase from an authorised Buro reseller (original receipt)
- Prove that the damage/failure is not through misuse or neglect.

To log your Guarantee Claim, please contact your Buro Reseller.

NEW ZEALAND	AUSTRALIA
29 Pukekiwiriki Place	2 Coronation Avenue
East Tāmaki	Kings Park
Auckland 2013	NSW 2148

Notes: Remove all items from the carton. Verify all pieces before assembly. Assemble desk on a clean, flat and soft surface. Only use included tools for assembly.

PARTS LIST - TOOLS & HARDWARE

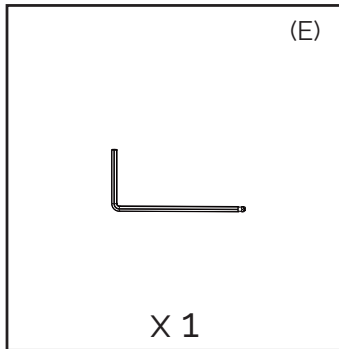
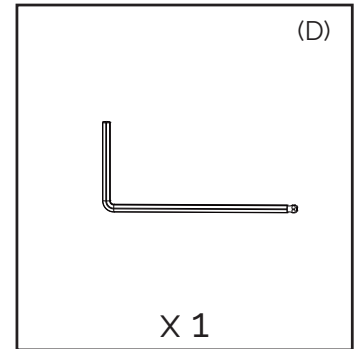
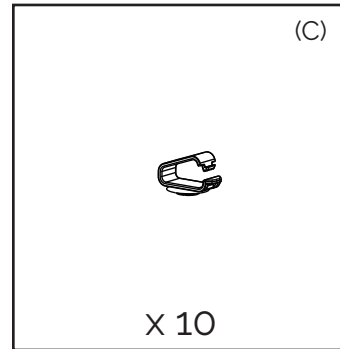
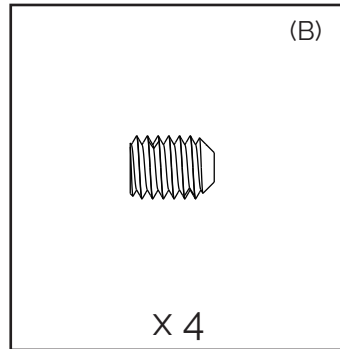
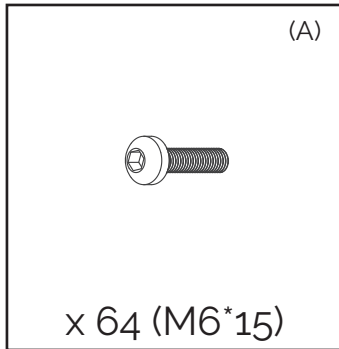

PARTS LIST - DESK TOPS

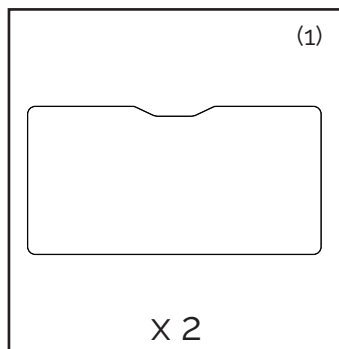

PARTS LIST - FRAME COMPONENTS

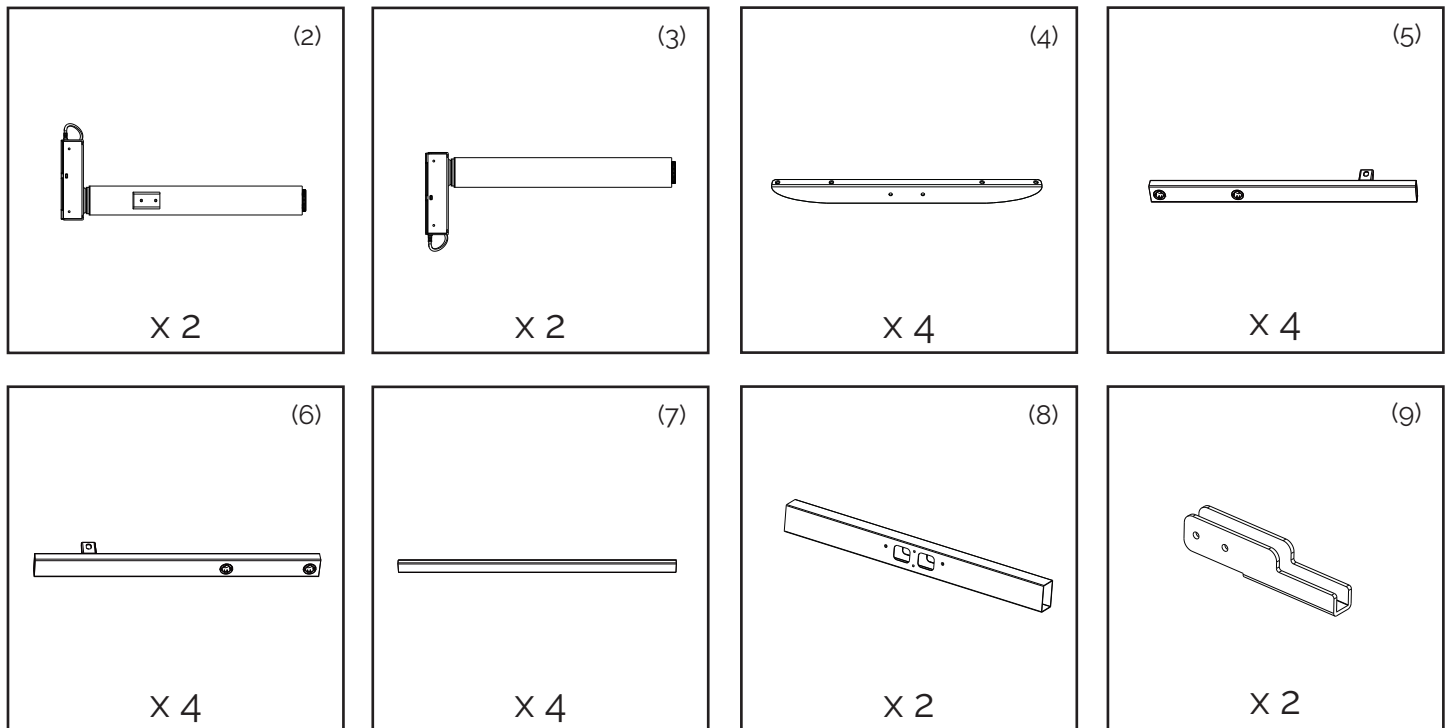

PARTS LIST - CENTRE CABLE TRAY

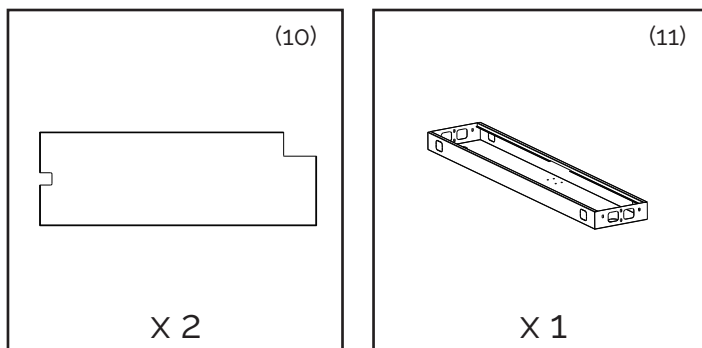

PARTS LIST - POWER SYSTEM

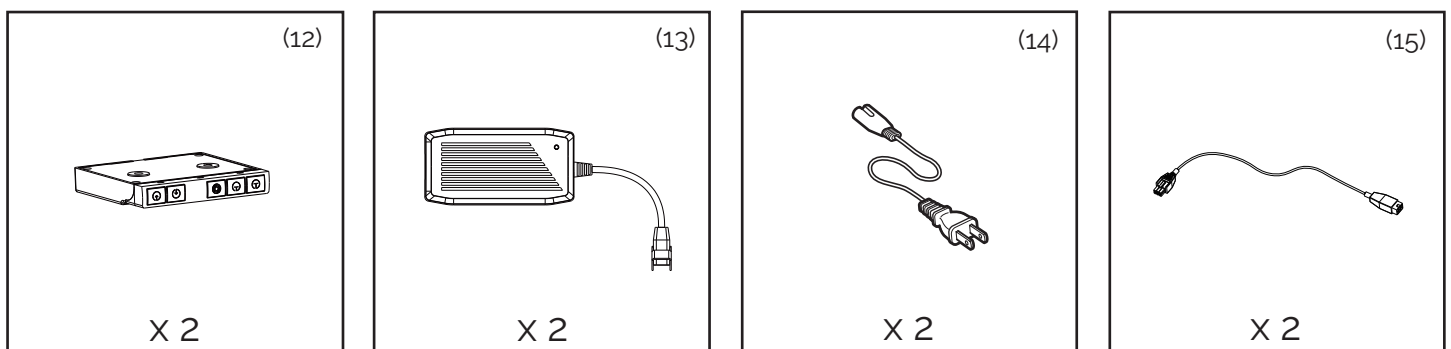

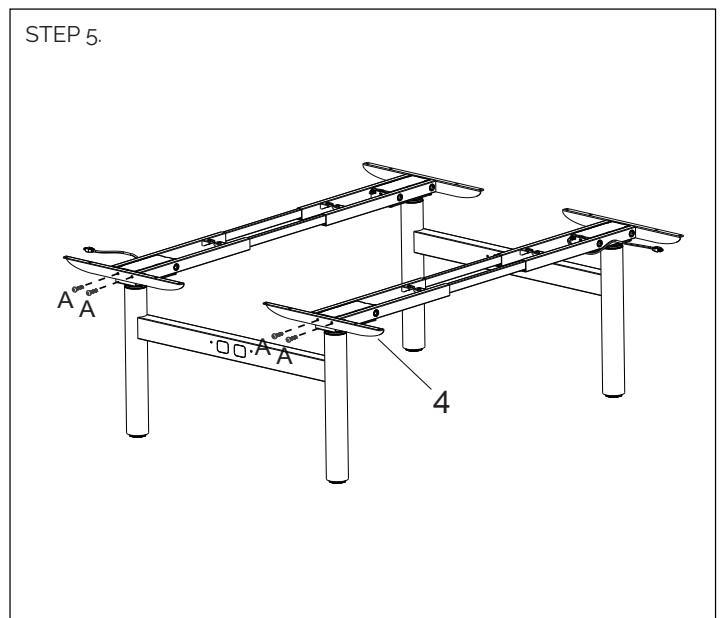
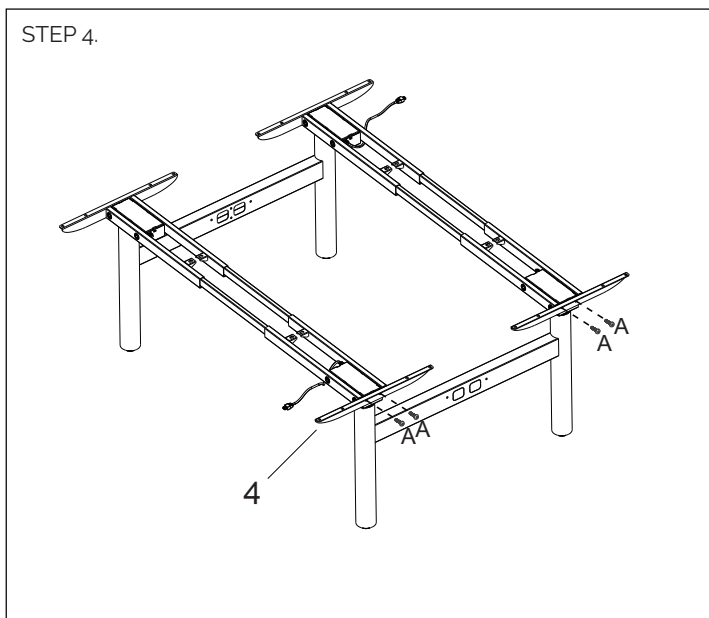
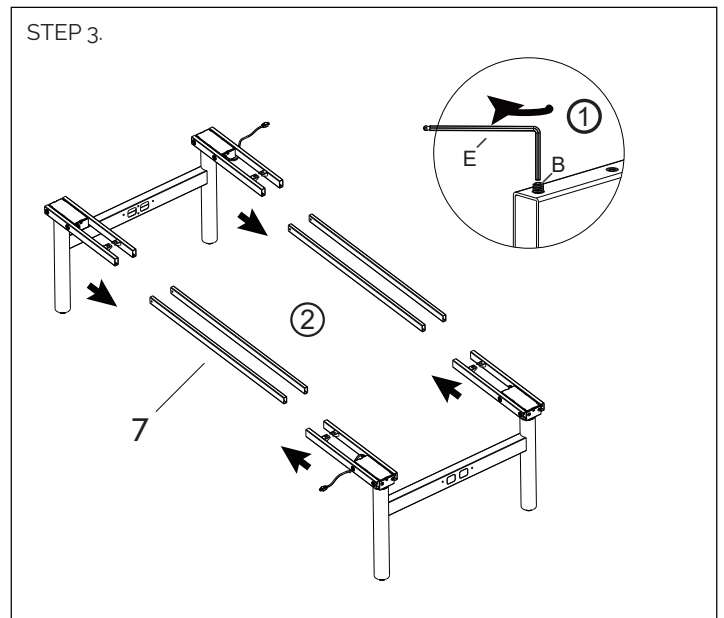
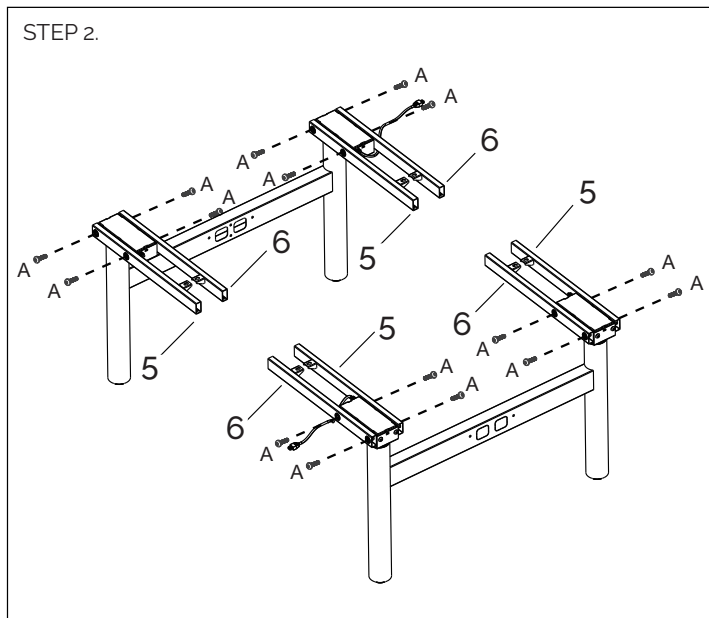
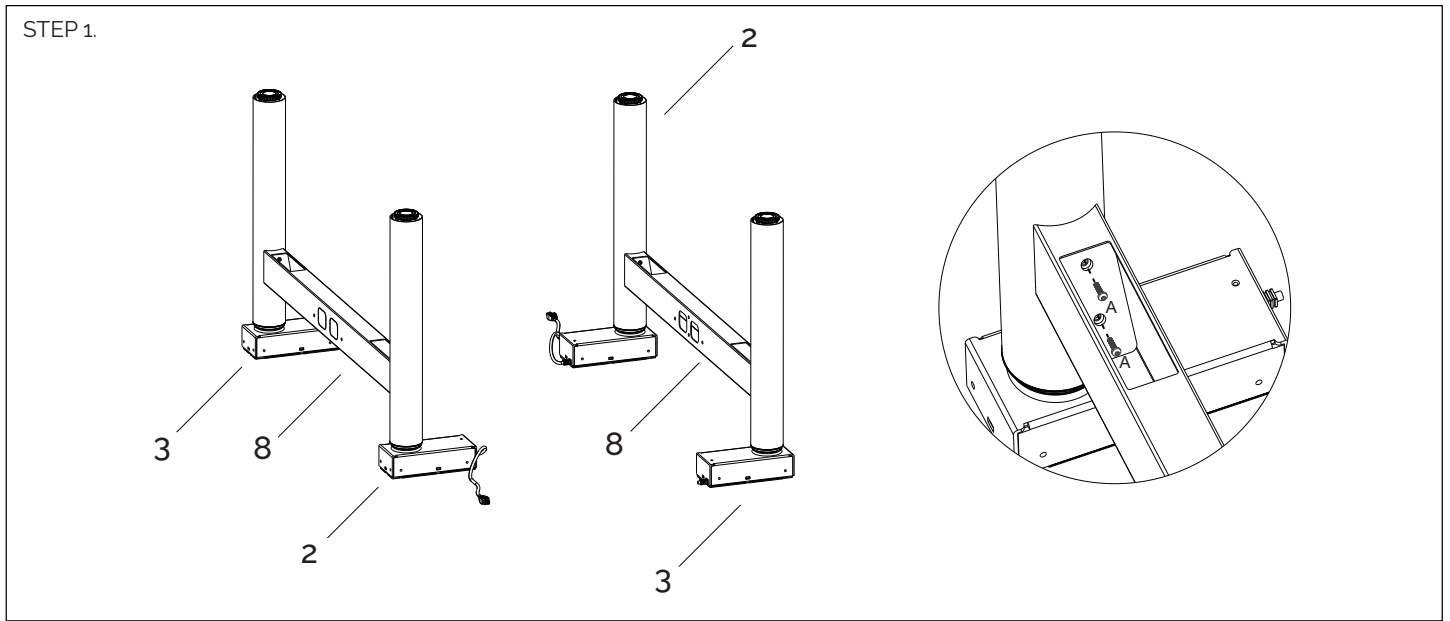

STEP 6.

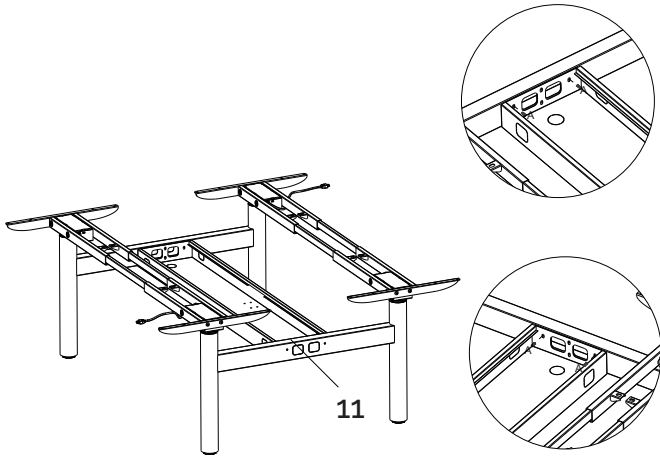

STEP 7.

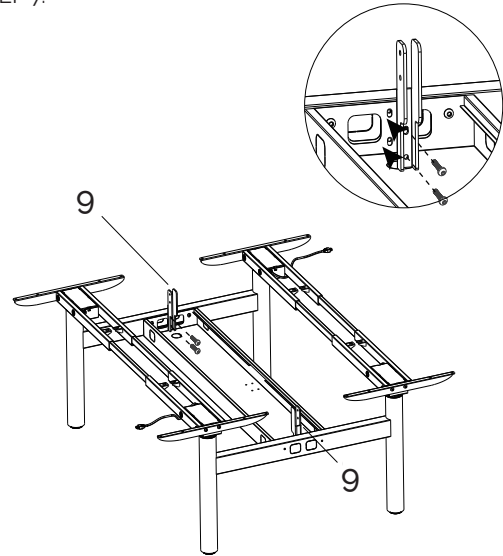

STEP 8.

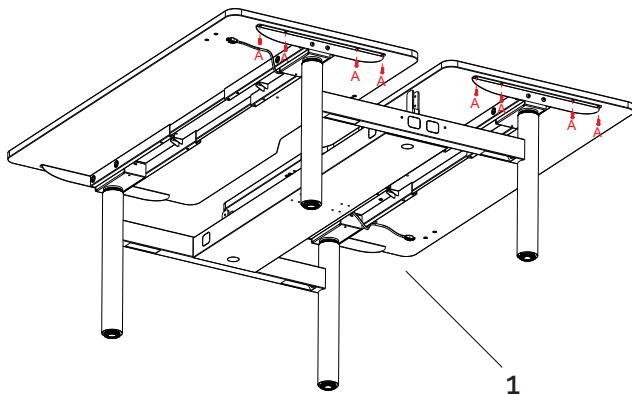

STEP 9.

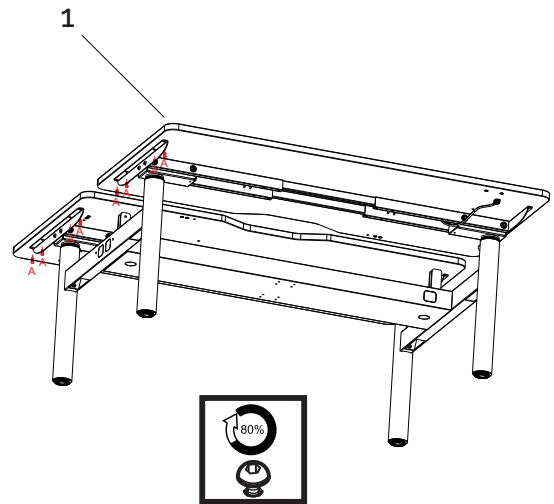

STEP 10.

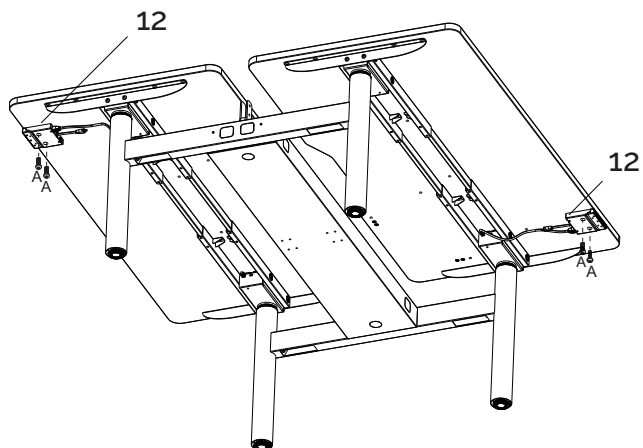

STEP 11.

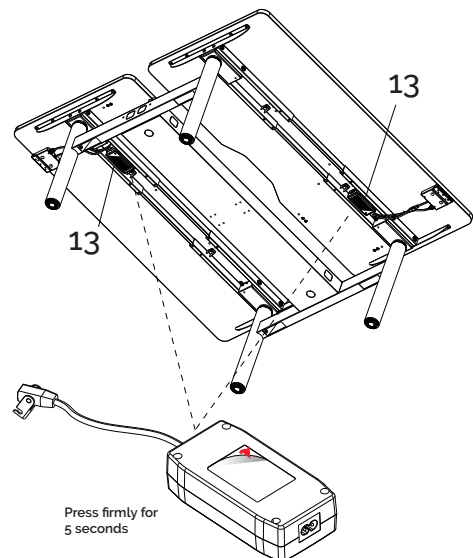

STEP 12.

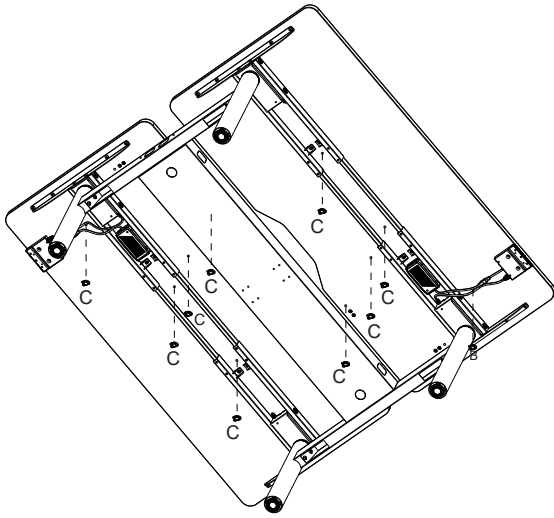

STEP 13.

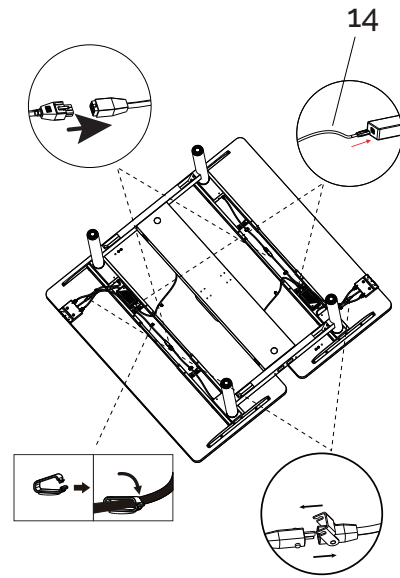

STEP 14.

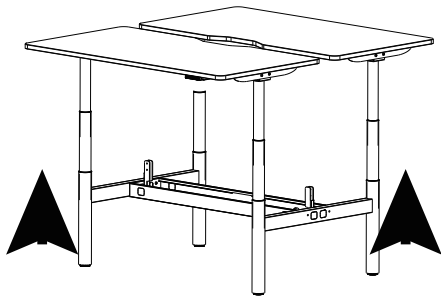

Raise the table

STEP 15.

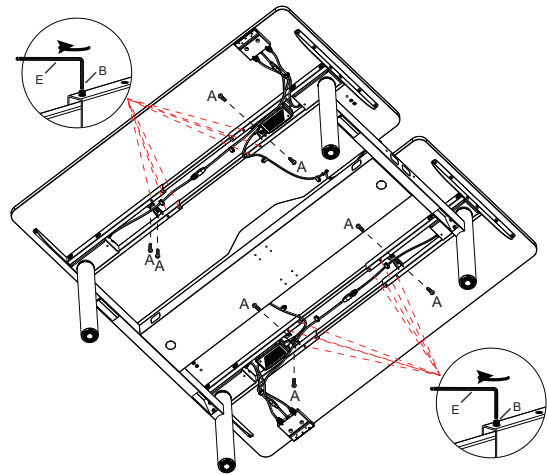

STEP 16.

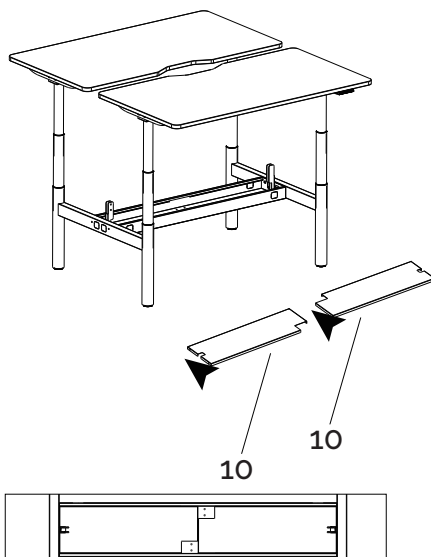

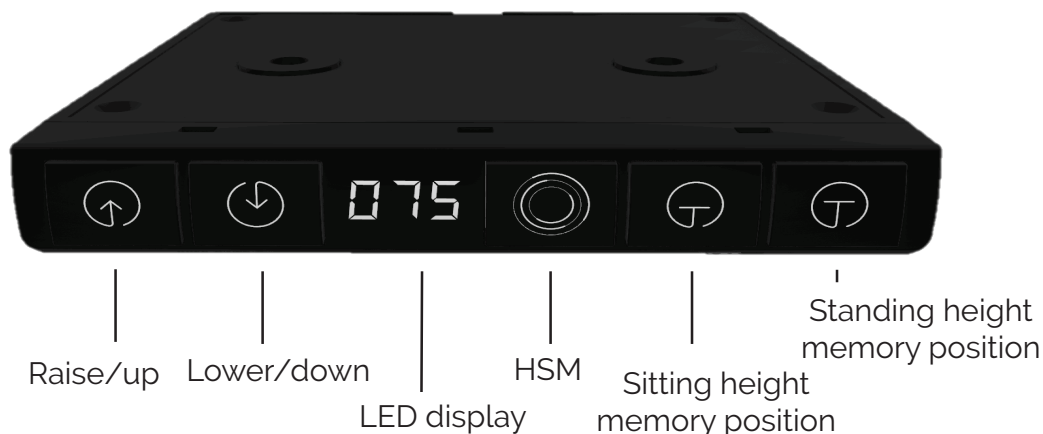

NOTICE

While raising or lowering the table, please make sure objects are secure on the table, and nothing prevents the table from raising or lowering through its desired range of adjustment.

SUGGESTION

Please set the preferred table height while sitting by pushing the "sitting position memory key", and the preferred table height while standing by pushing "the standing height memory key".

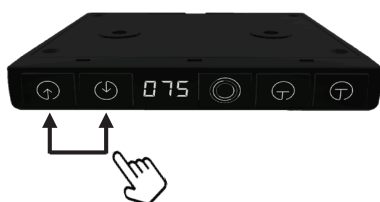
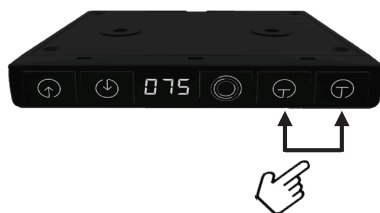



Table Height Adjustment

Press up  or down  to raise or lower the table to the preferred height.



press 3 + seconds

Memory Presets

At the preferred lower table height for sitting, press the left key  for 3+ seconds.

At the preferred higher table height for standing, press the right key  for 3+ seconds to set memory.

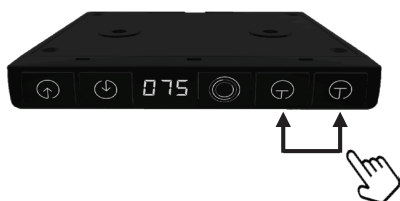

Use Of Memory Keys

Briefly press the left key  and release, the table will move to the preferred seated work height.

Briefly press the right key  and release, the table will move to the preferred standing work height.

 Table adjustment stops by pressing any key on the control pad.



HSM Mode-Healthy Spine Mode

When the light is flashing, the table will slowly move up 12cm in 3 minutes, then will stop for 2 minutes, and then will slowly move down by 12cm in 2 minutes. After 2 minutes, the movements will repeat.

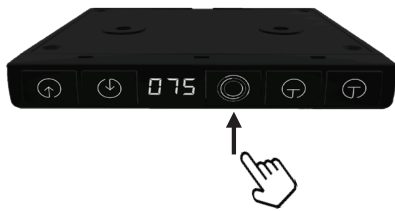
"The best posture is the next posture", Without breaking a sweat, you are, in fact, exercising your body.

Power ON/OFF

1. Press the  key to turn the operating system ON; the backlight light will be on;
2. The system automatically shuts off after 1 hour.
*If operating other keys, the backlight is off.

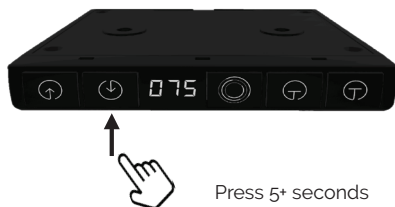

Reset Control Pad

In the lowest position, or when prompted by the "protection and alarm" message, press the down arrow for 5+ seconds, the table moves all the way down and will raise to a preset height at which time the reset is completed.

Notice: Objects under the table should be removed before the reset operation to prevent damage to table or other items

Recommendations:

- Healthy Spine Mode to be used while standing (not sitting).
- We recommend lowering the desk by around 6cm below your ideal standing height before activating HSM.
- If experiencing back or neck pain, consult a Health Professional for advice before using HSM.

Protection Features and Error Code Troubleshooting



Anti-interference: message/alarm "E02" appears when the desktop vibrates, is interfered with, or tilts during an adjustment. Stop adjustment immediately and reverse the movement. Once reversed enough, the alarm will disappear.



Overheating protection: message/alarm "Hot" appears when continuous adjustment time exceeds 2 minutes and the overheating protection will be triggered. Stop adjustment immediately; wait for 18 minutes and the alarm will disappear.



Motor malfunction protection: message/alarm "E10" appears. Power should be disconnected, re-check and ensure that the motor connected to the controller is secure, Connect to power source.



Overload protection; message/alarm "E20" appears when table is raised while overloaded. Remove heavy objects from the table before adjusting table height. If the overload alarm occurs when lowering the table, just press  for 5+ seconds to reset.



Out of Sync protection: message/alarm "E60" appears (multi-motor systems only!). Power should be disconnected, re-check and ensure that the motor connected to the controller is secure, then connect to power source to reset.